

**CHARACTERISTICS**

**POWER 230/400 V  
AT 1500 RPM - 50 Hz**

Type	CL. H (ΔT=125°C)						CL. F (ΔT=105°C)		CL. H (ΔT=125°C)		T.H.D. %
	THREE-PHASE		MOTOR STARTING	EFFICIENCY			THREE-PHASE		SINGLE-PHASE		
	KVA	KW COS φ 0,8		2/4 %	3/4 %	4/4 %	KVA	KW COS φ 0,8	KVA	KW COS φ 0,8	
<b>BTP3-1S/4</b>	7	5,6	KVA 32,5	76	80	79,4	6,5	5,2	5	KVA 24	< 3,5
<b>BTP3-2S/4</b>	9	7,2	KVA 40	78	82	81,2	8	6,4	6,5	KVA 30	< 3,5
<b>BTP3-1L/4</b>	11	8,8	KVA 50	82	84,2	83,9	10	8	8	KVA 38	< 3,5
<b>BTP3-2L/4</b>	13	10,4	KVA 62,5	83	85	83,9	12	9,6	9,5	KVA 45	< 3,5
<b>BTP3-3L/4</b>	15	12	KVA 65	84	85,5	84,4	14	11,2	11	KVA 50	< 3,5

**POWER 277/480 V  
AT 1800 RPM - 60 Hz**

Type	CL. H (ΔT=125°C)						CL. F (ΔT=105°C)		CL. H (ΔT=125°C)		T.H.D. %
	THREE-PHASE		MOTOR STARTING	EFFICIENCY			THREE-PHASE		SINGLE-PHASE		
	KVA	KW COS φ 0,8		2/4 %	3/4 %	4/4 %	KVA	KW COS φ 0,8	KVA	KW COS φ 0,8	
<b>BTP3-1S/4</b>	8,4	6,7	KVA 39	77,5	81,5	80,9	7,8	6,2	6	KVA 28	< 3,5
<b>BTP3-2S/4</b>	10,8	8,6	KVA 48	79,2	83,1	82,6	9,6	7,7	7,8	KVA 36	< 3,5
<b>BTP3-1L/4</b>	13,2	10,6	KVA 60	83	85,6	85,3	12	9,6	9,6	KVA 45	< 3,5
<b>BTP3-2L/4</b>	15,6	12,5	KVA 75	83,5	85,7	85,4	14,4	11,5	11,4	KVA 54	< 3,5
<b>BTP3-3L/4</b>	18	14,4	KVA 78	85	87	85,9	16,8	13,4	13,2	KVA 60	< 3,5

Type	J (Kg <sup>m</sup> <sup>2</sup> )			Peso (Kg)			Air Volume (m <sup>3</sup> /min)		Noise dB(A)				COUPLING DISCS	
	B3/B14	B3/B9	MD35	B3/B14	B3/B9	MD35	50 Hz	60 Hz	50 Hz		60 Hz		SAE N°	J(kg <sup>m</sup> <sup>2</sup> )*
							1m	7m	1m	7m				
<b>BTP3-1S/4</b>	0,0455	0,0452	0,0458	52	49	56	4,2	5,1	72	58	78	60	6 1/2	0,0067
<b>BTP3-2S/4</b>	0,0556	0,0554	0,0559	58	55	62	4,1	5					7 1/2	0,0103
<b>BTP3-1L/4</b>	0,0624	0,0622	0,0628	67	64	71	4	5					8	0,0171
<b>BTP3-2L/4</b>	0,0688	0,0686	0,0692	72	69	76	3,9	4,9					10	0,0319
<b>BTP3-3L/4</b>	0,0752	0,0750	0,0756	77	74	81	3,9	4,9					11 1/2	0,0481

\* The J value of form MD35 is obtained by summing the J of the MD35 form with the J of the chosen SAE coupling discs.

Type		BTP3-1S/4	BTP3-2S/4	BTP3-1L/4	BTP3-2L/4	BTP3-3L/4
Rating "H" class	kVA 50 Hz	7	9	11	13	15
Direct - axis synchronous reactance	X <sub>d</sub> %	157	179	170	158	160
Direct - axis transient reactance	X' <sub>d</sub> %	15,4	16	17	18,9	18
Direct - axis subtransient reactance	X'' <sub>d</sub> %	13	11,5	12	12,1	11
Quadrature - axis synchronous reactance	X <sub>q</sub> %	55	58	61	63	64
Quadrature - axis transient reactance	X' <sub>q</sub> %	55	58	61	63	64
Quadrature-axis subtransient reactance	X'' <sub>q</sub> %	63	63	63	56	58
Negative - sequence reactance	X <sub>2</sub> %	16,5	17	17,3	17,7	17,8
Zero sequence reactance	X <sub>0</sub> %	6,6	6,4	6,3	5,8	5,6
Transient time constant	T' <sub>d</sub> (ms)	28	18	38	46	50
Subtransient time constant	T'' <sub>d</sub> (ms)	27	12	14	10	10
Armature time constant	T <sub>a</sub> (ms)	12	13	48	11	12
Open circuit time constant	T' <sub>do</sub> (s)	0,78	0,8	0,81	0,83	0,85
Short - circuit ratio	K <sub>cc</sub>	1,08	0,87	0,93	1,04	0,97
Stator winding resistance	Ω	1,86	1,46	1,02	0,69	0,67

**ACCESSORIES**

REGULATOR	PARALLEL DEVICE	THERMAL PROTECTION			HEATERS	MECHANICAL PROTECTION			
COMPOUND TRANS.		PTC	BIMET DEVICE	PT100		IP21	IP23	IP45	IP55
●		<input type="checkbox"/>	<input type="checkbox"/>	<input type="checkbox"/>	<input type="checkbox"/>		●	<input type="checkbox"/>	<input type="checkbox"/>

● = Standard      □ = Optional



## OVERALL DIMENSIONS

021-58437

www.raddiesel.ir

راد دیزل نمایندگی ژنراتور مکاتنه ایتالیا

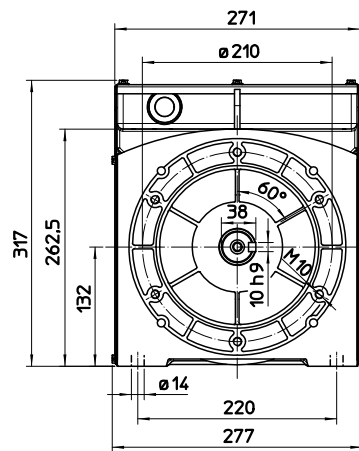
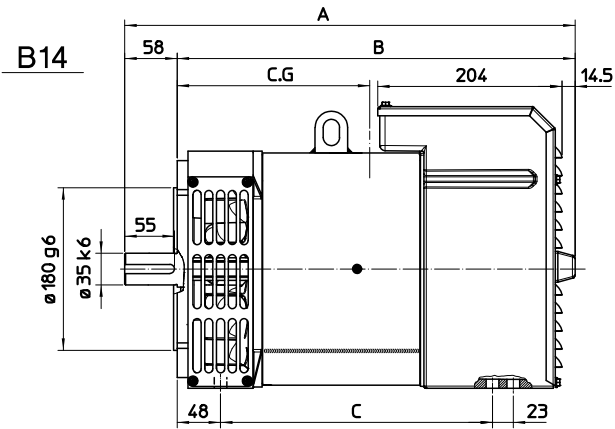

FORM	TYPE	A	B	C	E	F
B3B14	S	498	440	301	/	/
	L	568	510	371	/	/
B9	S	440	/	301	/	/
	L	510	/	371	/	/
J609b	S	440	/	301	146,1	165,1
	L	510	/	371	163,6	196,8
MD35	S	454	/	305	/	/
	L	524	/	375	/	/

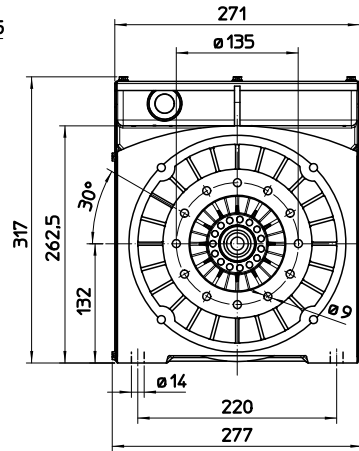
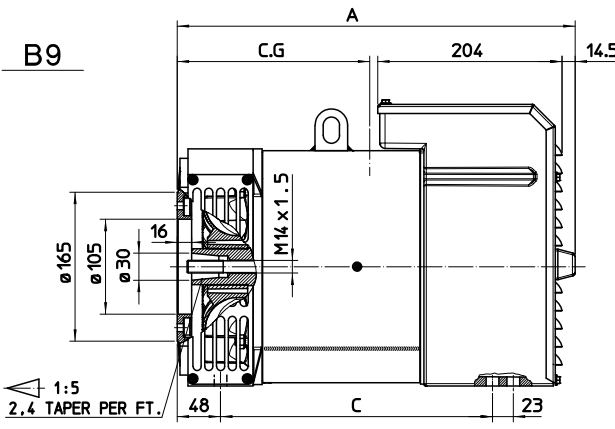

		C.G. = CENTRO GRAVITA GRAVITY CENTER			
		B3B14	B9	J609b	MD35
4 POLI 4 POLES	1S	221	225	230	230
	2S	210	213	218	220
	1L	259	262	267	266
	2L	252	254	259	259
	3L	244	247	250	252

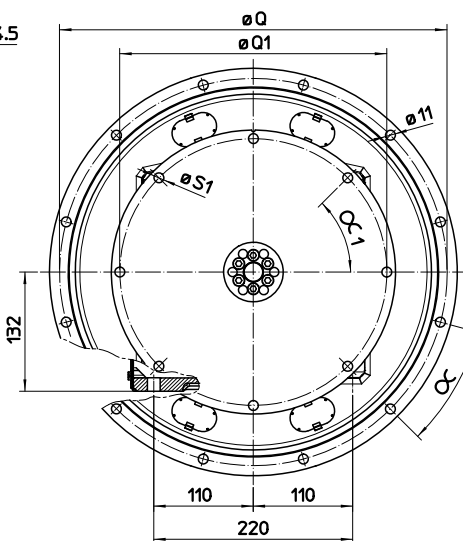
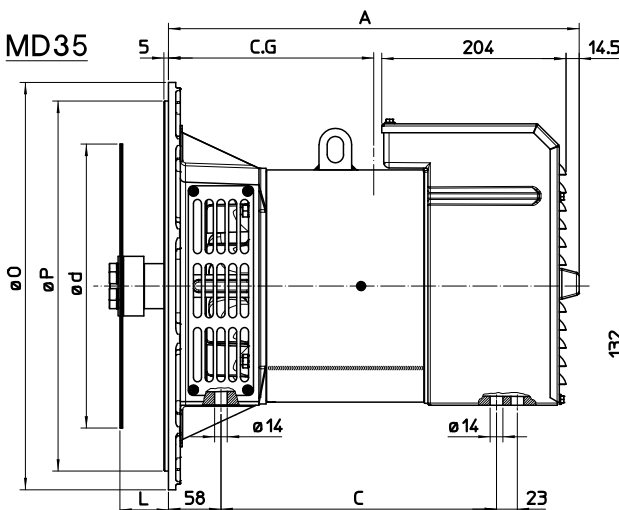
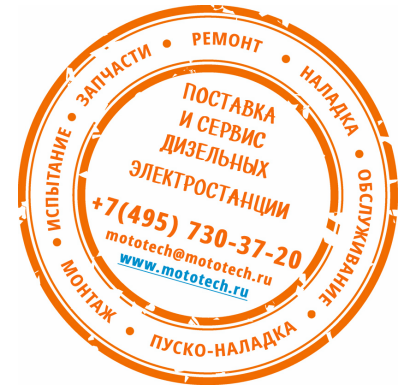
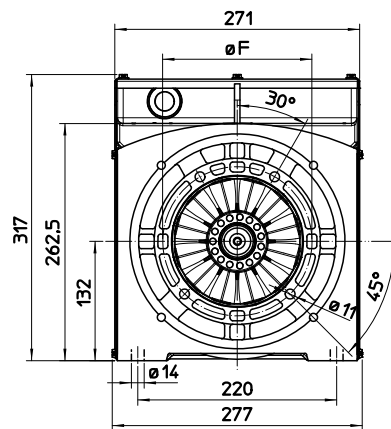
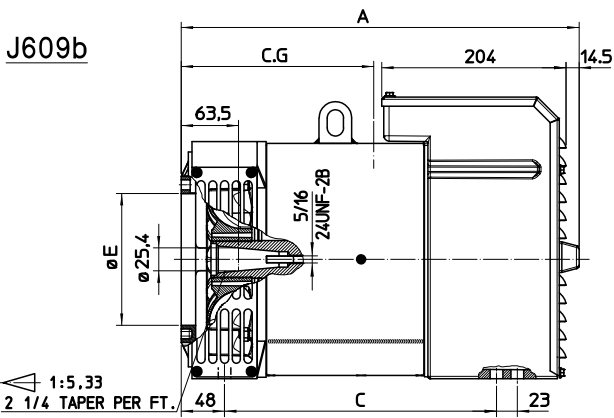

FLANGE					
SAE	O	P	Q	Fori N° Holes N°	∠
6	308	266.7	285.75	8	22°30'
5	356	314.3	333.4	8	22°30'
4	403	362	381	12	15°
3	451	409.6	428.6	12	15°

COUPLING DISCS						
SAE	L	d	Q1	Holes N°	S1	∠ <sub>1</sub>
6 ‡	30.2	215.9	200	6	9	60°
7 ‡	30.2	241.3	222.25	8	9	45°
8	62	263.52	244.47	6	11	60°
10	53.8	314.52	295.27	8	11	45°
11 ‡	39.6	352.42	333.37	8	11	45°