

راد دیزل نمایندگی ژنراتور استمفورد پاور

۰۲۱-۵۸۴۳۷

www.raddiesel.ir

RAD Diesel

系列三相无刷同步发电机
SERIES THREE-PHASE BRUSHLESS
SYNCHRONOUS ALTERNATOR



SLG354 TECHNICAL DATA SHEET

50Hz CLASS "H"

RATINGS	绕组形式 311 / 功率因数0.8 Winding 311 / 0.8 Power Factor															
	持续/125k/40°C Cont./125K/40°C								备用-150/40°C Standby-150/40°C							
定额/温升/环境温度 Duty / Temp Rise / Ambient T°	三相 3 PHASE															
相数 PHASE	三相 3 PHASE															
星形串联 SERIES STAR	380	400	415	440	380	400	415	440	380	400	415	440	380	400	415	440
星形并联 PARALLEL STAR	190	200	208	220	190	200	208	220	190	200	208	220	190	200	208	220
三角形串联 SERIES DELTA	220	230	240	254	220	230	240	254	220	230	240	254	220	230	240	254
双三角形并联 DOUBLE DELTA																
	KVA	KW	KVA	KW	KVA	KW	KVA	KW	KVA	KW	KVA	KW	KVA	KW	KVA	KW
SLG354C	450	360	450	360	450	360	450	360	478	382	478	382	478	382	478	382
SLG354D	500	400	500	400	500	400	500	400	515	412	515	412	515	412	515	412
SLG354E	600	480	600	480	600	480	600	480	636	509	636	509	636	509	636	509
SLG354FS	625	500	625	500	625	500	625	500	661.3	529	661.3	529	661.3	529	661.3	529
SLG354F	670	536	670	536	670	536	650	520	710	568	710	568	710	568	690	552

60Hz CLASS "H"

RATINGS	绕组形式 311 / 功率因数0.8 Winding 311 / 0.8 Power Factor															
	持续/125k/40°C Cont./125K/40°C								备用-150/40°C Standby-150/40°C							
定额/温升/环境温度 Duty / Temp Rise / Ambient T°	三相 3 PHASE															
相数 PHASE	三相 3 PHASE															
星形串联 SERIES STAR	416	440	460	480	416	440	460	480	416	440	460	480	416	440	460	480
星形并联 PARALLEL STAR	208	220	230	240	208	220	230	240	208	220	230	240	208	220	230	240
三角形串联 SERIES DELTA	240	254	266	277	240	254	266	277	240	254	266	277	240	254	266	277
双三角形并联 DOUBLE DELTA																
	KVA	KW	KVA	KW	KVA	KW	KVA	KW	KVA	KW	KVA	KW	KVA	KW	KVA	KW
SLG354C	525	420	550	440	581	465	594	475	550	440	581	465	613	490	625	500
SLG354D	575	460	594	475	625	500	644	515	588	470	625	500	655	524	675	540
SLG354E	681	545	713	570	731	585	750	600	719	575	750	600	780	624	800	640
SLG354FS	700	560	725	580	731	585	775	620	718.8	575	767	613.6	780	624	800	640
SLG354F	738	590	775	620	800	640	825	660	781	625	819	655	848	678	875	700

راد دیزل نمایندگی ژنراتور استمفورد پاور

۰۲۱-۵۸۴۳۷

www.raddiesel.ir

双轴承 DOUBLE BEARING

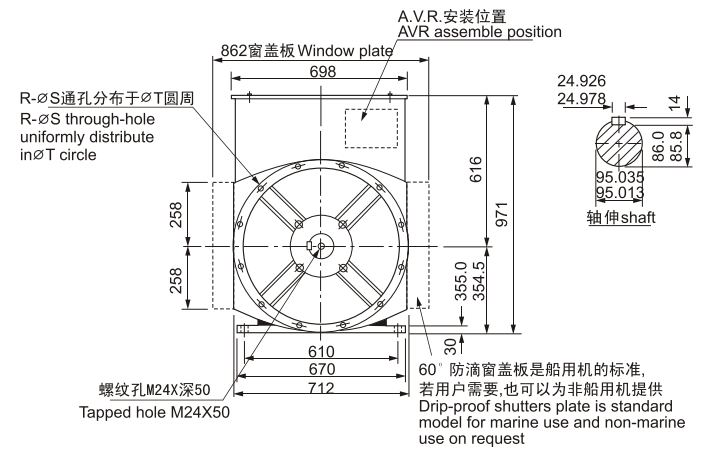
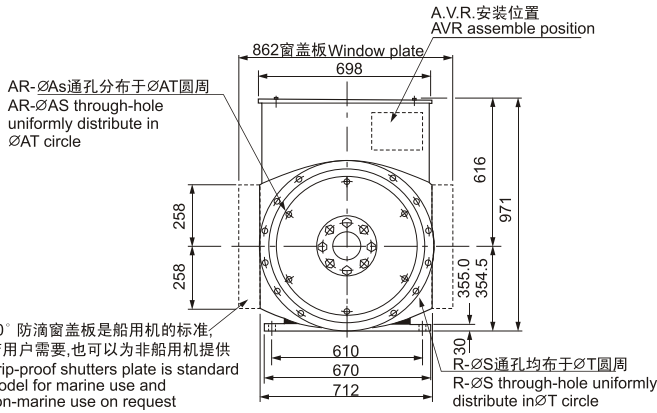
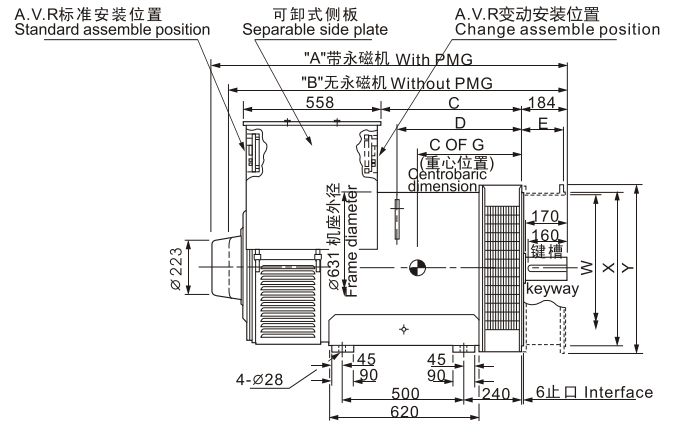
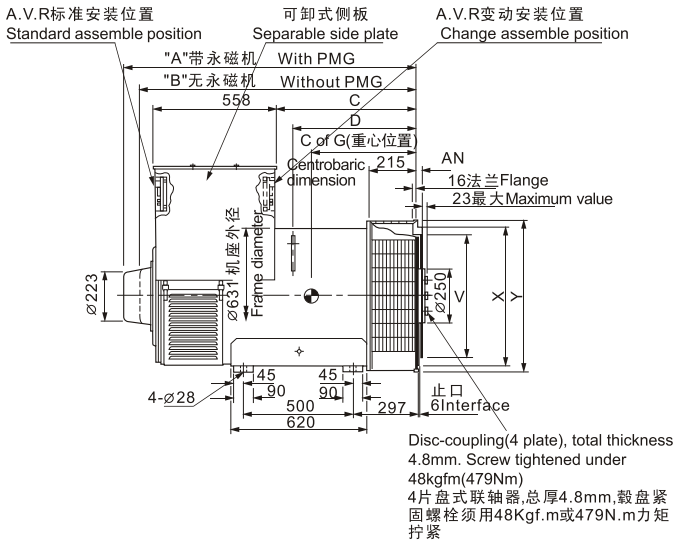

DIMENSION 尺寸(mm)

型号 Model	A	B	C	D	C of G	N.W (kg)	G.W (kg)	LXWXH (mm)
SLG354C	1337	1266	642	568	555	1265	1350	1430X830X1230
SLG354D	1337	1266	642	568	575	1230	1450	1430X830X1230
SLG354E	1337	1266	642	568	595	1500	1598	1430X830X1230
SLG354FS	1412	1341	717	643	620	1580	1678	1500X830X1230
SLG354F	1412	1341	717	643	620	1680	1753	1500X830X1230

DIMENSION 尺寸(mm)

型号 Model	A	B	C	D	C of G	N.W (kg)	G.W (kg)	LXWXH (mm)
SLG354C	1464	1393	585	511	498	1275	1375	1500X830X1230
SLG354D	1464	1393	585	511	518	1330	1430	1500X830X1230
SLG354E	1464	1393	585	511	538	1530	1630	1500X830X1230
SLG354FS	1539	1468	660	586	565	1740	1840	1580X830X1230
SLG354F	1539	1468	660	586	565	1690	1790	1580X830X1230

FLANGE 法兰式过渡接套 (mm)

S.A.E.NO.	R	S	T	X	Y
00	12	14	850.9	787.3	882
0	12	14	679.5	647.6	711
1/2	12	14	619.1	584.1	700
1	12	12.7	530.2	511.1	700

FLANGE 法兰式过渡接套 (mm)

S.A.E.NO.	R	S	T	W	X	Y	E
00	16	14	850.9	772	787.3	882	170
0	16	14	679.5	634	647.6	711	170
1/2	12	14	619.1	569	584.1	648	150
1	12	12.7	530.2	496	511.1	553	170

DISC COUPLING 盘片式联轴器 (mm)

S.A.E.NO.	AN	AR	AS	AT	V
14	25.40	8	13.5	438.2	466.6
18	15.87	6	16.7	543.0	571.4
21	0	12	16.7	641.3	673.0

SINGLE BEARING SAE NO SELECTOR 单轴承驱动片和过渡法兰配套表

	SAE14	SAE18
SAE 0	•	•
SAE 0.5	•	
SAE 1	•	

RAD Diesel

021-58437